



BUTCHER BLOCK COUNTERTOP INSTALLATION INSTRUCTIONS

3601 S. Banker St. Effingham, IL 62401 • P.O. BOX 609 • Ph: (888) 431-2667 • Fax: (800) 433-2667

RECEIVING YOUR BUTCHER BLOCK TOP

It is very important to open and inspect the product when it is delivered. **DO NOT SKIP THIS STEP.**

- If shipping damage has occurred, it must be noted on the bill of lading at the time of delivery.
- If concealed damage is discovered after the delivery, it must be reported to the freight company within 14 days of delivery. However, compensation for concealed damage claims is at the sole discretion of the carrier, and may not cover the cost of repair or replacement.
- If damage is not noted at the time of delivery or within 14 days of delivery in the case of concealed damage, the product is assumed to have been received in good condition and becomes the sole property of the receiving party.

ACCLIMATING YOUR BUTCHER BLOCK TOP

Your butcher block should be placed in the room where it will be installed for a minimum of 72 hours prior to installation. The heat or air conditioning (whichever applies) should be controlling the environment during the acclimation period. This allows the wood to stabilize in the new environment.

- Remove the packaging and allow the butcher block to have free airspace on the top and bottom during acclimation. Set the block on 2 x 4s on edge, 12" to 18" apart, to keep the block off the floor and allow air to circulate.
- Do not lay the block directly on the floor as this may cause cupping. Allowing the block to adjust to the new environment prior to installation is a critical step in the installation process.

INSTALLING YOUR BUTCHER BLOCK TOP

When installing Butcher Block Countertops, it is very important to remember that all natural hardwood products continue to move throughout their useful life. Changing temperatures and humidity levels will cause wood to expand and contract. **Installation methods must allow the top to be able to move during changing conditions or seasons.**

- First, **do not attach directly on top of a solid underlayment.** Remove prior top. If a solid particle board or MDF top is the underlayment, have large holes cut into them to assist with even and adequate ventilation.
- The appropriate length #10 screws and washers should be carefully chosen so the screw does not go all the way through the top but the depth of penetration is enough to secure the top in place. Generally, the screw should go ½ the thickness of the countertop, except for 4" and 7" thick tops where 1 to 1 ½" penetration is adequate. (Screw length is determined by the sub-top thickness + pilot hole penetration.)
- Place the block in the location that it will be installed. Allow 1/8" of room for expansion at each end when the top is trapped between 2 walls. The gap can be concealed with backsplash material or the trim of your choice.
- **Butcher Block Surfaces should never be glued down with silicone caulk or construction adhesive** as this will prevent natural movement and result in damage to the top. Cracking and warping when tops are installed using construction adhesive or silicone caulk will not be covered under warranty.
- Minimal fixing is required as the tops will be held down by self weight. Use only enough fasteners to secure the block. Too many fasteners can keep the top from moving freely and result in damage. Fastener locations are usually in the corners.
- The first hole drilled should be the pilot hole. Use a 5/32" drill bit for the pilot holes. The pilot hole should be deep enough to accommodate the full length of the screw. Screwing into the wood without a pilot hole will cause outward pressure and may crack the wood.

- Then, drill a 3/8" expansion hole in the sub-top or screw block in the same location as the pilot hole, being careful not to drill into the underside of the butcher block: repeat for each fastener. Tops that are screwed down without expansion holes will also be void of warranty. **(See Diagram 1)**
- On the underside of the sub-top, place the washer on the screw and drive the screw into the pilot hole in the butcher block. Be careful not to over tighten. Make sure the washer is large enough to cover the expansion hole.
- **Countertop joints should not be glued. Use the draw bolt fasteners provided or consult an installation expert in your area for acceptable installation practices.** (Reference drawings for your custom project if provided by John Boos & Co.)
- If your layout includes any overhangs, note that overhangs of 8" and greater will require additional support corbels or brackets at least every 24 inches. **(See Diagram 3)**

INSTALLING BACKSPLASHES

Wood backsplash material may be screwed to the butcher block prior to installation by drilling pilot holes and screwing from the bottom of the block into the backsplash material. **(See Diagram 2)** Expansion holes are not necessary for the attachment of the backsplash.

- For the application of backsplash materials only, silicone caulk may also be used in lieu of attaching with screws.

INSTALLING AROUND APPLIANCES

Additional considerations should be made when installing a butcher block countertop around appliances and countertops with sink and stove cutouts.

- Where appliances have heat acting on the counter top, insulation should be installed to cut down heat transference. Provide adequate ventilation.
- The fitting of sinks and cooktops must not restrict the counter top from expanding and contracting. Ensure that there is at least 1/4" clearance all around the appliance. Insulation should be installed around cooktops. Rubberized joint sealant should be used in sink applications.

ALSO SEE THE CARE AND MAINTENANCE GUIDE INCLUDED WITH YOUR PRODUCT

CONTINUE TO PAGE 3 FOR DIAGRAMS

DIAGRAM 1

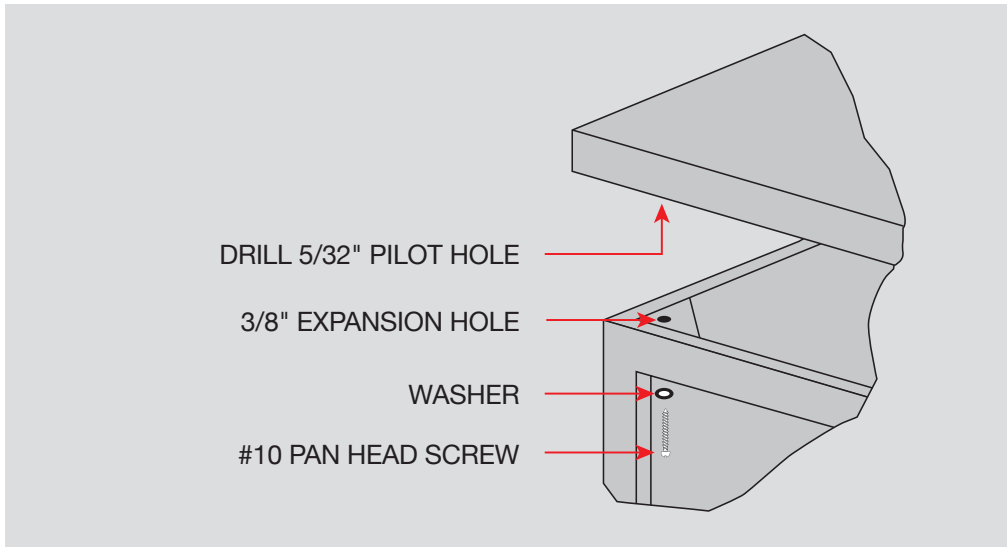

DIAGRAM 2

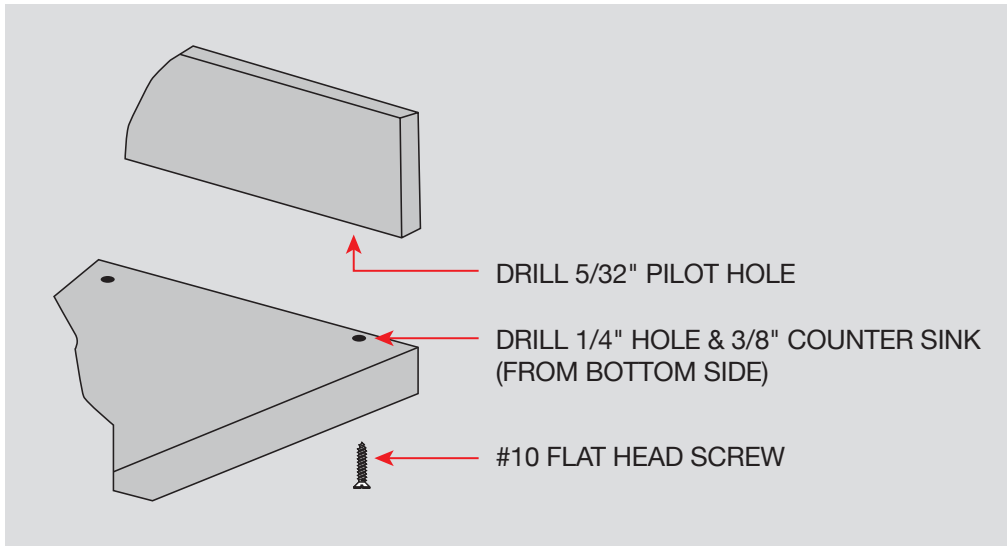

DIAGRAM 3

