

THE BLOCKS THAT MADE BOOS FAMOUS



Saratoga Farm Block (SARB)

FEATURES:

- * Solid Hard Rock Maple
- * 4" Thick End Grain Work Surface
- * Finished with Penetrating Oil
- * Stand 32" O.A.H.
- * Optional White Lacquer Base Color (**Must Specify**)
- * Options: Casters (CAS04)
- * Shipped knocked-down, easy - to - assemble
- * UPSable

Model	Size	Wt
SARB1	24"x24"	105
SARB2	30"X24"	120

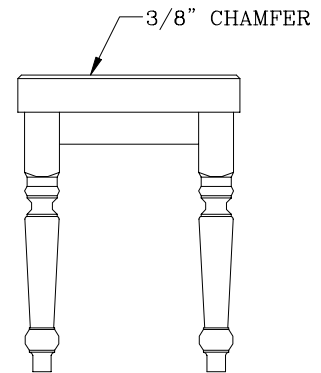
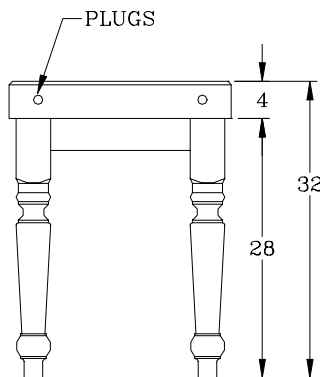
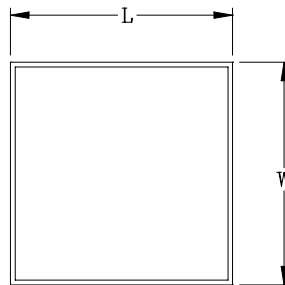

MATERIAL:

Top: End Grain Hard Rock Maple
 Legs: Hard Rock Maple

John Boos & Co

315 South First Street - Effingham, IL 62401
 Phone: 217-347-7701 - Fax: 217-347-7705
 Email: sales@johnboos.com - Web-site: www.johnboos.com